

PENDULUM BUCKET ELEVATORS

Triton Innovation's Pendulum Bucket Elevators simultaneously execute vertical and horizontal transportation of dry, bulk material within a compact footprint. Offering virtually limitless configurations, multiple infeed and discharge points, and effective management of high volumes of product for various processing, production, and packaging applications.

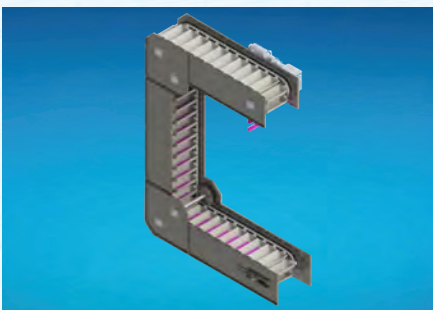
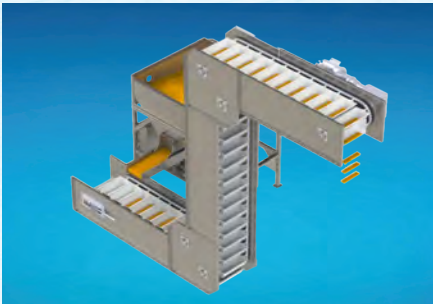
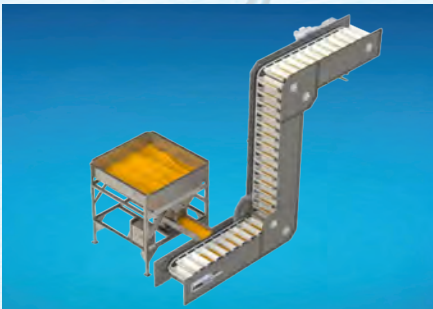

- Modular design enables ongoing flexibility and versatility.
- Multiple infeed and discharge points.
- Gentle handling of both fragile and non-fragile material.
- Buckets are made with FDA or sanitary materials designed for easy, tool-less removal.
- Easily cleanable design enhances efficiency for batch and recipe changeovers.
- Buckets overlap to eliminate product spillage. Tapered shape enhances product release, promotes complete removal, and reduces accumulation points.
- Common configurations: Z-Style, C-Style, E-Style, Inclined Z-Style, Double Z-Style. Custom configurations available upon request.

COMMON CONFIGURATIONS

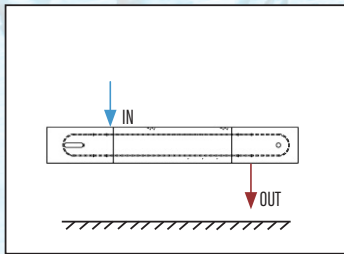

HORIZONTAL

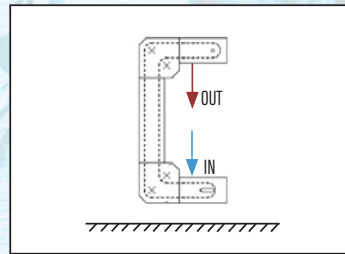

C-STYLE

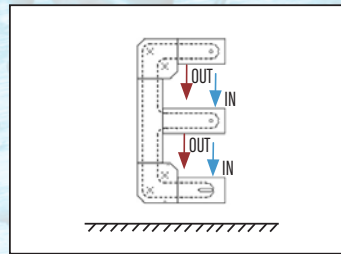

E-STYLE

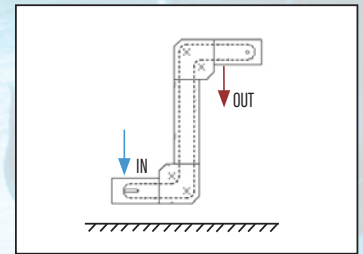

Z-STYLE

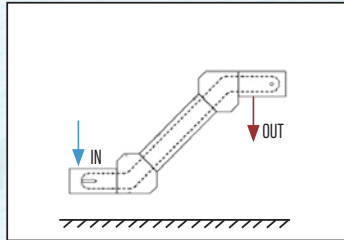

ANGLED Z-STYLE

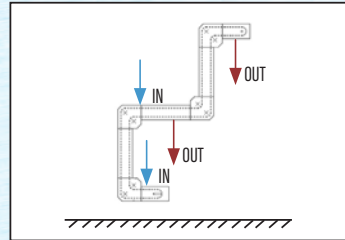

DOUBLE Z-STYLE

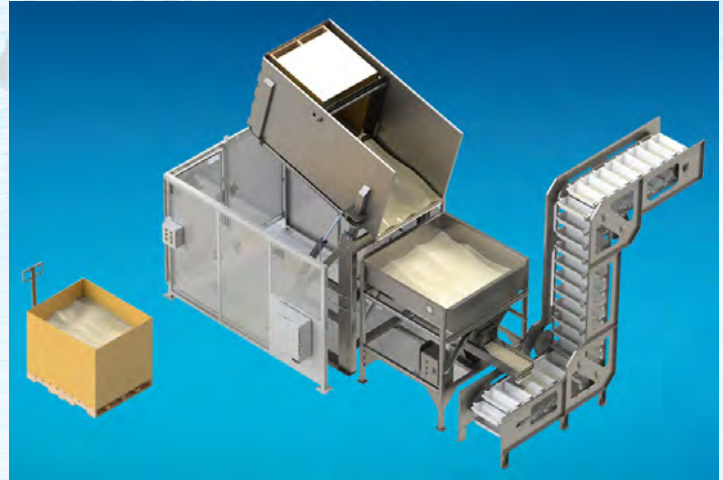

APPLICATIONS & PRODUCTS

COMMON APPLICATIONS

BULK UNLOADING

WEIGHING

FILLING

PACKAGING

PROCESSING

COOKING

MIXING & BLENDING

BATCH PROCESSING

COMMON INDUSTRIES AND PRODUCTS



PET FOOD
AND TREATS



PASTA
AND GRAINS



FRUITS
AND VEGGIES



NUTS



HERBS
AND SPICES



CONFECTIONARY
AND CANDY



BAKERY



DAIRY
AND CHEESE



SNACK
FOODS



PILLS
AND TABLETS

STANDARD FEATURES

- **Triton Innovation LLC's** food handling equipment can be designed to meet your specific FDA, USDA or BEAG sanitary application requirements.
- **Hygienic Level I for Dry Environments** – Non-Washdown Designs, Non-Washdown Carbon Steel Bucket Chain, Carbon Steel Frame/Leg Materials, FDA-H1 Lubricants, FDA Powder Coated Frame/Legs, NEMA-1 Electrical/Control Items, Stainless Steel Shafts with FDA Materials, Stitch Welded Frame/Legs, Non-Washdown Drive, Welds Cleaned but Not Ground, FDA Buckets
- **Hygienic Level II for Dry to Wet Environments** – Washdown Designs, Stainless Steel Washdown Bucket Chain, Stainless Steel 2B Mill Finish Frame/Leg Materials, FDA-H1 Lubricants, Stainless Steel Shafts with FDA Materials, NEMA-4X Electrical/Control Items, Epoxy Painted Washdown Drive, Stitch Welded Frame/Legs, FDA Buckets, Welds Cleaned but Not Ground
- **Hygienic Level III for Dry to Wet Environments** – Hygienic Open/Cleanable Designs, Stainless Steel Washdown Bucket Chain, Stainless Steel 2B Mill Finish Frame/Leg Materials, FDA-H1 Lubricants, Stainless Steel Shafts with FDA Materials, NEMA-4X Electrical/Control Items, Stainless Steel Washdown Drive, Continuously Welded Frame/Legs, FDA Buckets, Welds Coarse Ground & Cleaned, Clean-out Ports in Sideframes

OPTIONS

- Ceiling Hangers
- Infeed Guides/Discharge Chutes
- Bucket Scrapers
- Top Covers: Stainless Steel, Bolt-On, Hinged, Lift Off, or Flat. Lexan Viewing Windows
- Start/Stop, E-Stop Controls
- Maintenance doors



TOP COVERS



CASTERS



DISCHARGE CHUTE

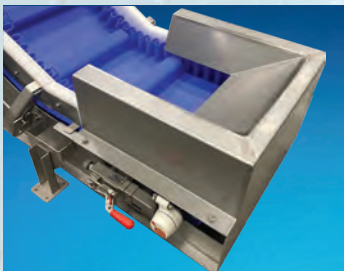

INFEED GUIDES



AC CONTROLLER (VFD)



CIP SPRAY BAR



VIBRATORY FEEDER

PRODUCTS AVAILABLE FROM TRITON INNOVATION, LLC



DUMPER/TIPPER



FABRIC BELT CONVEYOR



HOMOGENEOUS BELT CONVEYOR



MODULAR PLASTIC BELT CONVEYOR



TROUGHED BELT CONVEYOR



WIRE MESH BELT CONVEYOR



METERING FEEDER SYSTEMS

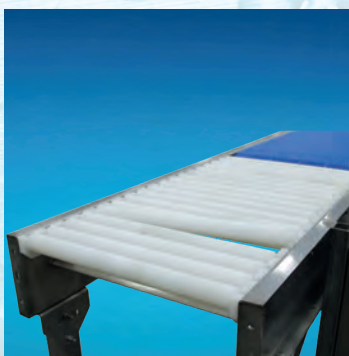

SPECIALTY PRODUCTS

Scan for more information located on our website

